



# Cermax IS

## Portable Dewpointmeter



The hygrometer of choice for the measurement of dew-point temperature or moisture content in hazardous area gas applications



*Cermax IS  
Portable Dewpointmeter*



### Features

- Easy to use
- Extremely fast response
- High accuracy and repeatability
- ATEX, FM and CSA certified for hazardous area use
- User friendly display
- Data logging facility
- Lightweight construction
- Long battery life

### The Most Advanced Portable Hygrometer

Cermax IS provides raw performance, rugged reliability and advanced features for measuring the dew point of non-flammable and flammable gases within petrochemical, natural gas plants and other hazardous areas. It provides the site chemist and operational staff with an effective means to check the moisture concentration at any point in their process. Cermax IS is also perfect for any industrial application requiring safe measurement of flammable gases, such as hydrogen used as coolant for electricity generator sets or as a controlled furnace atmosphere for heat treatment of metals.

### Easy Operation

Cermax IS is fully self-contained - no external services are required. Simply connect a clean sample gas to the Swagelok® inlet port, turn on the power and within seconds Cermax is ready to display the measured dew point of the sample gas under test. The advanced user interface allows you to decide whether to make a simple measurement or to perform more complex functions, like pressure compensation, range selections, input scaling, data logging, etc. For more demanding process applications a range of 'bolt-on' sampling systems are available.

### Extremely Fast Response

Our users always rate a fast speed of response as a key feature of a portable hygrometer. Cermax IS has been designed particularly with this feature in mind. With an inherently fast Ceramic Moisture Sensor and a minimum volume stainless steel sample housing Cermax IS has a head start on the competition. Add to this Cermax IS's user selectable field operation mode, which allows even ppm level measurements to be made in a few minutes, and the result is a world-class hygrometer with superior performance.

### High Accuracy and Repeatability

The combination of advanced sensor technology and measurement circuitry give Cermax IS a standard measurement range from -100 to +20 °C dew point and indication down to -120 °C and up to +30 °C dew point. Cermax IS offers a measurement accuracy of ±1 °C dp in the range +20 to -59.9 °C dp and ±2 °C dp in the range -100 to -60 °C dp. Resolution, etc (as per Cermax standard).

### Intrinsically Safe Certification

*Cermax IS is certified by Baseefa (2001) Ltd for use in hazardous areas to  II 1G EEx ia IIC (155 °C) T3 and also FM (USA) listed to intrinsically safe CL1, Div1, GpA, B, C & D T3C and CSA (Canada) to Ex ia IIC T3 (Class 1, Div 1, Groups A, B, C & D).*



The Dew Point Specialists



## User Friendly Display

The programmable display interface powers up in default mode giving an almost instant display of the measured dew point. For the user who needs more sophistication, a drop down menu system allows easy selection of a secondary input display of alternative engineering units, pressure and temperature corrections, tagging and logging of measured data, and downloading (to a host device such as a PC). The menu system quickly becomes second nature to operate.

## Data Logging Facility

Cermax IS features a logging system that can store up to 10,000 measurement points. The logger will store both dew point and the second process variable (temperature or pressure), along with tag and time information. Logging start time, interval and test duration are all selected from the instrument's drop down menu. Once the log has been taken, data can be downloaded onto a PC using Windows™ Terminal or a similar data transfer program.

## Lightweight Construction

Weighing a total of 3 kg, Cermax IS is one of the lightest intrinsically safe portable instruments available. This is not, however, at the expense of robustness. The strong moulded polyurethane carry case gives the optimum combination of physical strength and low mass and is practical too, giving an IP65 protection rating (NEMA 4 equivalent).

## Long Battery Life

Cermax uses a sealed rechargeable battery pack that gives an average usage time of more than 24 hours between charges, at normal room temperature. The battery pack is easily removable and spare battery packs are available so that the instrument can be permanently operational, if required.

## Technical Specifications

<i>Gas wetted parts</i>	316 stainless steel
<i>Gas connections</i>	1/8" Swagelok® inlet and outlet couplings
<i>Display</i>	4 line x 40 character LCD
<i>Range</i>	Calibrated from -100 to +20 °C dew point; readings to -120 and +30 °C dew point
<i>Accuracy</i>	±1 °C from -59.9 to +20 °C dew point; ±2 °C from -100 to -60 °C dew point
<i>Resolution</i>	0.1° C dew point (3 significant figures for all other units)
<i>Units</i>	°C, °F, K dew point; ppm <sub>v</sub> ; ppm <sub>w</sub> for air, N <sub>2</sub> , H <sub>2</sub> , SF <sub>6</sub> , CO <sub>2</sub> , natural gas; gm <sup>-3</sup> (natural gas); Lb/mmscf (natural gas)
<i>Data storage</i>	Up to 10,000 samples, time and data stamp and ident number
<i>Communications</i>	RS232C
<i>Power</i>	Internal re-chargeable battery pack charged by external AC powered charger (supplied). 24 hours normal operation between charges
<i>Case</i>	Custom polyurethane case with integral padded carry handle
<i>Dimensions</i>	250W x 300D x 150H mm approx
<i>Weight</i>	3 kg
<i>Ingress protection</i>	IP65 (NEMA 4)
<i>Operating temp</i>	-20 to +40 °C
<i>Storage temp</i>	-65 to +65 °C
<i>Operating pressure</i>	30 MPa (max)
<i>Flow rate</i>	0.5 to 5 Nlmin <sup>-1</sup>
<i>Intrinsic safety</i>	Certified to IIG EEx ia IIC (155°C) T3 through Baseefa (2001) Ltd Certificate No Baseefa03ATEX0090X FM: Certificate J.I.6D5A0AX CSA: File No LR 114519-1
<i>Optional extras</i>	Carry bag; shoulder strap; sampling systems; spare battery pack

## Dimensions

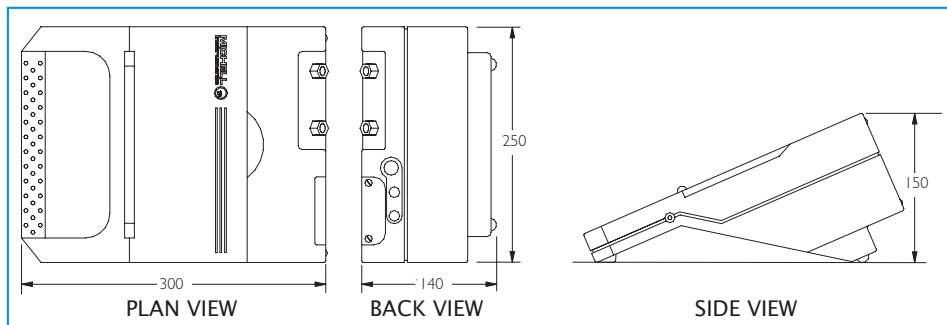

Dimensions mm