



# Easidew

## On-line Hygrometer



An economical panel- or bench- mounting hygrometer with digital display, analogue and digital outputs, and dual alarm feature, offering excellent reliability and repeatability



*Easidew  
On-line*

### Features

- Wide measurement range
- 2 user selectable alarms
- Large red LED display
- Digital and analogue outputs
- 1/8 DIN panel mounting
- Cable length up to 800 m
- °C or °F dewpoint
- Universal power supply

### Affordable, Simple Dew Point Measurement

The Easidew On-line Hygrometer has been designed to make continuous measurement of the dew point in air and gases simple and reliable. The neat 1/8 DIN display unit is connected to the Easidew Transmitter sensor module, which may be permanently installed in a plant or process location at a distance of up to 800 m from the display. An analogue output is provided for re-transmission to a chart recorder or data-logger and two alarm relays, adjustable via the front panel touch switches, providing control outputs.

### Intelligent and Interchangeable Sensor Technology

The key to Easidew's performance is its sensor technology. Michell's Advanced Ceramic Moisture Sensor is coupled with the latest microprocessor based measurement circuitry to produce a fully calibrated and interchangeable sensor transmitter module. All calibration data is stored within the memory and so sensor exchange for calibration or service can be effected in seconds, even by untrained personnel. Furthermore, the transmitter module can be used as a stand-alone dew-point transmitter if required (see Easidew Transmitter datasheet for full specifications). This same intelligent sensor transmitter is used in the Easidew Portable Hygrometer. Total flexibility, interchangeability and ease of implementation.

### Continuous In-Process Measurement

Easidew On-line is designed to give you continuous, reliable measurement of your air or gas system. The Easidew Transmitter puts intelligent dew-point control right at the measurement point, transmitting calibrated data back to the monitor unit, which can be located anywhere up to 800 m away. Thus, you can be sure that the Easidew On-line Hygrometer will always be giving you vital, real-time information on the quality of air from your dryer system, or the gas in your process line. Easidew On-line's sensor can operate at any pressure up to 30 MPa (300 Barg) when used with its stainless steel sampling block, supplied as standard. The Easidew On-line can also be used with the Easidew Sampler (see Easidew Sampler datasheet). The Sampler is a self-contained sampling system providing filtration and flow control for either pressure or atmospheric dewpoints.

### Measurement in Your Control

The Easidew On-line Hygrometer features an extremely clear and bright 20 mm red LED display, so you can easily see the dew point of your process even in poor light conditions. We also provide you with a 4-20 mA analogue or RS232 digital output for connection to a chart recorder, data-logger or computer system, so you can analyse trends in dew point over time. In addition, the Easidew On-line includes 2 alarms that can be easily configured by the user. Each of these alarms has a relay contact. This feature makes the Easidew On-line ideal for the monitoring and control of desiccant dryers or other critical applications.



**The Dew Point Specialists**



## Practical Design

The Easidew On-line Hygrometer is a compact hygrometer, with a standard 1/8 DIN layout (96 x 48 mm) requiring clearance depth of only 85 mm. Front panel buttons for alarm setting are protected to IP65 and NEMA 12.

## Reproducibility and Calibration Integrity

It is vital that the dew-point measurements you make are accurate and reliable. For over thirty years we have continually developed and refined our sensor technology to ensure that every sensor performs to your expectations. Each Ceramic Moisture Sensor goes through a multi-mode test and inspection process before calibration to verify it's reliability. The calibration process itself takes more than one week, where rigorous checks on the sensor performance are carried out at thirteen points across the measurement range. Only when the sensor has passed all these stringent checks is it ready to be applied to your critical process control application.

## Traceable Calibration

Each Easidew On-line is supplied with a calibration certificate traceable to national standards from Michell Instruments UKAS accredited laboratory

## Technical Specifications

<i>Measurement Range</i>	-100 to +20 °C dew point -148 to +68 °F dew point
<i>Accuracy</i>	±2 °C dew point
<i>Operating Temp</i>	Electronics: -5 to +50 °C Sensor: -40 to +60 °C
<i>Storage Temperature</i>	-40 to +75 °C
<i>Output</i>	4-20 or 0-20 mA signal, max load resistance 500 W RS232
<i>Alarm</i>	2 volt free contacts, 3A @ 240 VAC
<i>User interface</i>	Front panel configuration of alarm points
<i>Power Supply</i>	85 to 264 VAC, 50/60 Hz
<i>Ingress protection</i>	IP65 and NEMA 12 front panel only
<i>Sensor Cable</i>	0.8 m supplied as standard (max 800 m)
<i>Mains Cable</i>	2 m cable supplied
<i>Dimensions</i>	Monitor: 1/8 DIN case, 96 x 48 x 85 mm including clearance (W x H x D) Sensor: 132 x 27A/F mm (length x diameter across hex flats)
<i>Sensor</i>	For full specification please see the Easidew Transmitter datasheet
<i>Options:</i>	Easidew Sampler

## Dimensions

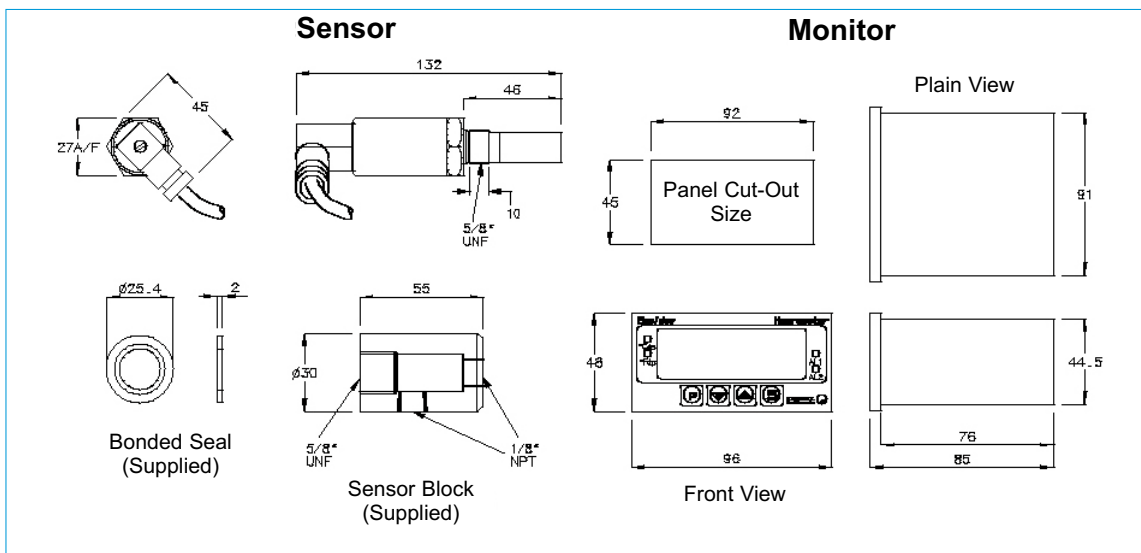

Dimensions mm



Q6284 (UK)



0179 (UK)



**The Dew Point Specialists**