



Cermet II IS

Hygrometer

From the Impedance Range

For continuous dew point measurements in hazardous areas with safe area display, Cermet II IS is the ideal on-line hygrometer solution with full certification by ATEX, FM and CSA



*Cermet II IS
Hygrometer*



Features

- Easy to install
- High accuracy, repeatability and long-term reliability
- Low maintenance
- Measurement accuracy up to ± 1 °C dew point
- Fast speed of response
- Multiple user units, alarms and pressure correction
- Analogue and digital outputs

Complete Dew Point Solution for IS Areas

Cermet II IS is an easy to install, self-contained hygrometer system for measurement of the moisture content of flammable and non-flammable gases within hazardous areas. It comprises an intrinsically safe transmitter, Transmet IS, and a safe area Cermet II IS Control Unit. Housed in a stainless steel case, the Transmet IS transmitter offers ingress protection to IP66 (NEMA 4X). The Cermet II IS Control Unit is a 19" sub rack unit containing display, transmitter power supply and isolation barriers suitable for location in a designated safe area. It provides all necessary user interfacing, including multi-unit display, alarms, analogue and digital outputs. Control unit and transmitter are connected by up to 500 metres of cable via galvanic isolation barriers.

Simplicity

Cermet II IS measures the gas under test either by direct insertion of the transmitter into the gas line or by diverting a sample of the gas through its (optional) flow-through stainless steel sample housing. Once the Transmet IS transmitter has been connected to the gas sample and Cermet II IS Control Panel, it is ready to use. The Cermet II Control Unit is pre-configured to the most common user settings and an easy to use push-button interface allows the user to select a number of features and variables including alarm adjustment, displayed engineering unit and pressure compensation. Of course, for certain applications pre-conditioning of the process gas may be necessary to achieve the correct pressure, or to remove particulate or entrained liquid contaminants. Michell can provide a range of standard or customised sample conditioning systems as a package with Cermet II IS.

User Interface Options Reliability is Vital

Cermet II IS has a wide range of standard features to make interfacing simple. A clear LED display can be set to provide indication in °C or °F dew point or ppm_v. Units of Lb/mm³ and gm⁻³ provide an enhancement to the characteristics of pressurised natural gas. The Cermet II IS Control Unit can accept a pressure transducer input for active pressure compensation or, via front panel selection, give passive adjustment. A linear 4-20mA output, calibrated to the displayed parameter, can be ranged and scaled from the front panel. Two 10A relays are fully adjustable and a further two can be added as options. Two-way RS232 communication is provided allowing data transmission and on-line configuration.

A hygrometer must operate reliably over its total operating range, in the user's demanding operational environment. The Transmet IS transmitter has been designed to cope with extreme industrial conditions and is resistant to shock, vibration and extremes of temperature and operating pressure. Furthermore, the advanced design of the Michell Ceramic Moisture Sensor, coupled with extremely competent measurement circuitry, give Cermet II IS a class leading accuracy, repeatability and measurement range at pressures up to 30 MPa - in even the most exacting of process conditions, such as natural gas processing (even for extremely sour gas) or catalytic reformer gas measurement.



The Dew Point Specialists



Certified Intrinsically Safe

Cermet II IS provides an intrinsically safe solution that is certified by the major international bodies. Transmet IS is ATEX certified by EECs for use in hazardous areas to Ex II 1G EEx ia IIC T4 when used with a pair of isolation or shunt diode barriers for signal and power supply connections. Transmet IS has been FM listed (USA) CL1, Div1, GpA, B, C & D, T4 and CSA (Canada) certified to Ex ia (Class 1, Groups A, B, C & D). Cermet II IS can therefore be safely used in virtually any industrial gas measurement application.

Applications

Cermet II IS can be applied to almost any air or gas dew-point measurement application situated in a classified hazardous area. Typically Cermet II IS will be used for the fiscal metering of natural gas dew point, of the moisture content in catalytic reformer gases, or in the measurement of hydrogen coolant for power plant stators. Cermet II IS can of course also be used to measure the dew point of inert gases used in hazardous areas - compressed air systems or inert purge gases used for pipeline and vessel drying and pressure testing. A range of sampling systems are available.

Dimensions

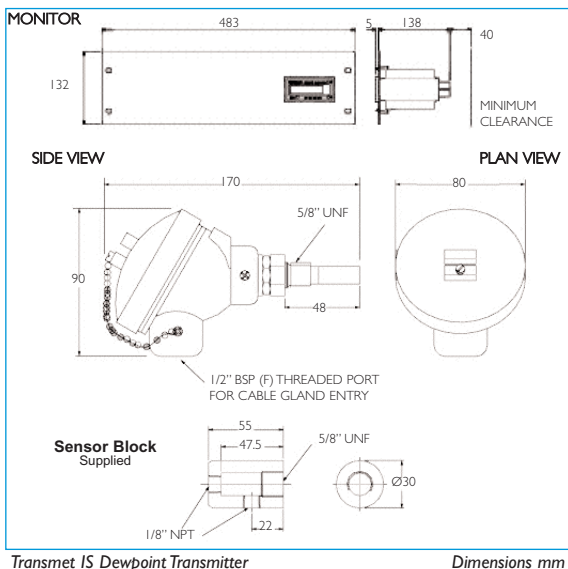

Technical Specifications

Cermet II IS

Measurement range	-100 to +20 °C dew point
Accuracy	±1 °C from +20 to -60 °C dew point; ±2 °C from -60 to -100 °C dewpoint
Other units	Digital processing linearisation with pressure compensation from measured dew point with pressure compensation to any other preferred unit - Lb/mm ³ and mg/Nm ³ (for natural gas), ppm _v with active or passive pressure compensation
Pressure input	Fixed value (user programmed) or dynamic measurement (4-20 mA pressure transmitter; optional)
Resolution	0.1 °C dp, 0.1 °F dp, 0.01 ppm _v , 0.1 mg/m ³ , 0.01 Lb/mm ³
Analogue output	4-20 mA isolated (max load 600W)
Sensor calibration	Traceable to British (NPL) and American (NIST) National Humidity Standards
Power supply	Universal 85 to 265 V AC; 90 to 370 V DC
Alarms	Two user adjustable for set points and operating configurations
Mounting panel	19" anodised aluminium, '3U' high 132 x 200 mm clearance depth
Additional PSU	For Transmet IS. 24 V DC clip-on rail type
Barriers	2 galvanic isolation type
Control Unit Options	
Power supply	Low voltage version 18 to 36 V AC; 9 to 60 V DC
Relays	1 or 2 further 5 A relays (max 4 in total) n/o type fully user configurable: can accommodate full range + full unit choice + sensor fault alarm functions
Outputs: analogue	0-10 V fully user configurable and scaleable for range
digital	RS485: provides 2-way communication - full data access to user + total availability of all set-up and configuration

Transmet IS Transmitter

Sensor thread	5/8" UNF parallel
Case	Stainless steel
Ingress protection	IP66 (NEMA 4X)
Power	Derived from Cermet II IS control unit
Operating temp	-20 to +60 °C
Storage temp	-40 to +70 °C
Operating pressure	From vacuum to 30 MPa
Flow rate	0-10 Nlmin ⁻¹
Gas velocity	20 ms ⁻¹ (max)
Interconnecting Sensor Cable Options	
Field cable spec	Polyethylene insulated instrumentation cable to BS5308 Part 1 - two collectively screened dual conductors 0.5 mm ² . Polyethylene bedding, galvanised steel wire armour, and PVC flame retardant outer sheath in blue. Low smoke and fume or halogen free outer sheath options available
Max length	250 m (greater dependent upon cable spec)

Safety Aspects

The Cermet II IS Hygrometer meets the requirements of BS5345: Part 1: 1989 and other European codes of practice for Zone 1 potentially hazardous area operation of the sensor and sample conditioning system to analyse gases of all gas groupings inclusive of IIC. The Cermet II IS Control Unit must be located in a designated non-hazardous area (or in an optional EExd housing).

Transmet IS is ATEX certified by EECs for use in hazardous areas to Ex II 1G EEx ia IIC T4 when used with a pair of isolation or shunt diode barriers for signal and power supply connections. Transmet IS has been FM listed (USA) CL1, Div1, GpA, B, C & D, T4 and CSA (Canada) certified to Ex ia (Class 1, Groups A, B, C & D).