

Transmitter HX-772

- RH, Dew Point, and Absolute Humidity versions
- Completely sealed electronics
- Low cost
- Small size ½" dia x 3.2" (ø12 x 80 mm)
- Excellent linearity
- Digitally adjustable, no potentiometers



The HX-772 Transmitter combines standard analog outputs, easily interchangeable with older sensors, with microprocessor correction for improved accuracy and linearity. The standard HX-772 provides a linear analog output signal of 0-1 V or 0-5 V directly proportional to 0-100% RH.

In addition to digital correction, it features a rugged potted housing, and a miniature electrical connector for easy removal. The unit has completely sealed

electronics and meets CE requirements.

The HX-772 is also available in absolute humidity and dewpoint versions, which use the microcontroller to accurately calculate dewpoint or absolute humidity from the measured RH and temperature values.

The HX-772 utilizes a thin-film polymer humidity sensor that provides excellent long-term stability and fast response. The sensor fully recovers from condensation.

Because the HX-772 output is corrected with a microcontroller, it shows excellent linearity, and an accuracy of ±2% Relative Humidity from 5 to 95 % RH.

The microcontroller eliminates the need for adjustment potentiometers, which can be a source of error.

The compact size, durability and versatility make the HX-772 the ideal choice for all applications that require the accurate monitoring of humidity or dewpoint.

Typical Applications

- ▶ Climate Chambers
- ▶ Incubators
- ▶ Bakery machines
- ▶ Greenhouses
- ▶ HVAC installations
- ▶ Energy management

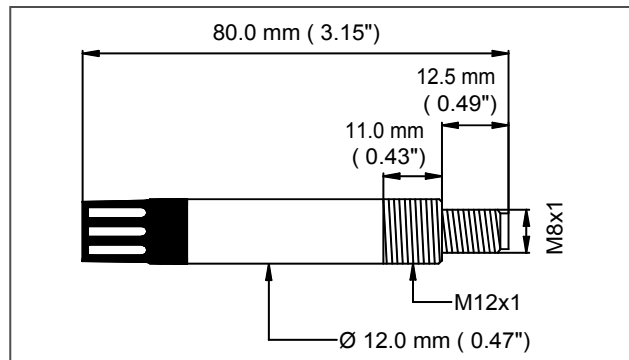

Transmitter HX-772

| | |
|----------------------------|--|
| Humidity Transmitter Range | 0 to 100% RH |
| Outputs available | 0 - 1 Vdc or 0 - 5 Vdc, 1 mA max. |
| Working RH range | 5 - 95% RH |
| Accuracy @ 25 °C | ± 2% RH from 5 - 95%RH |
| Response time | 10s typical without filter (90% of the change) |
| Stability | ±2% RH, 24 months typical, depending on environmental conditions |
| Supply influence | ± 0.01% RH per Volt typical |
| Operating temp. | -20 to +70 °C |
| Dewpoint Range | -40 to +60°C |
| Output | 0 - 5 Vdc |
| Accuracy | the accuracy of this derived value depends on the accuracy of the measured RH and temperature values |
| Abs. Humidity Range | 0 - 200 g/m ³ |
| Output | 0 - 5 Vdc |
| Accuracy | the accuracy of this derived value depends on the accuracy of the measured RH and temperature values |
| Power supply (excitation) | 8 - 35 Vdc, 1.3 mA |
| Housing Dimensions | ½" dia x 3.2" (ø12 x 80 mm) |
| Case Material | Plastic |
| Environmental Protection | Electronics IP65, sensor IP30 |

All specifications are subject to change without prior notice

| Ordering information | |
|----------------------|--|
| Model | Description |
| HX-772-I-01 | Relative Humidity Transmitter 0 - 1Vdc out |
| HX-772-I-02 | Relative Humidity Transmitter 0 - 5Vdc out |
| HX-772-I-03 | Dewpoint Transmitter |
| HX-772-I-04 | Absolute Humidity Transmitter |
| Part number | Accessories |
| A-000003 | Protection cap with slotted openings |
| A-000012 | Teflon filter |
| A-000013 | Protection cap with Teflon filter |
| A-000022 | Protection cap with wire-mesh filter |
| A-000023 | Sintered stainless steel filter |
| A-000033 | Electrical Connector, with 6ft (2m) cable |
| A-000111 | Flange, aluminum |

HEAD OFFICE



Process Measurement & Controls, Inc.
Rense Instruments Division

11 Old Sugar Hollow Road
 Danbury, CT 06810 U.S.A.
 Tel: 203-792-8686
 Fax: 203-743-2051
 Email: sales@renseinstruments.com
www.renseinstruments.com

Represented By: