

**Transmitter HT-737**

- Relative Humidity, Temperature, Dewpoint and Absolute Humidity
- Digitally adjustable – no potentiometers
- RS-232 or RS-485 output
- Fast response from thin film polymer sensor



The HT-737 transmitter measures temperature and ambient relative humidity, dewpoint or absolute humidity, and provides a digital output that can be connected directly to a computer with a standard serial interface. It features digital zero and span adjustment, a rugged housing and a threaded electrical connector.

Model HT-737-V-00 has an RS-232 output, whereas model HT-737-V-01 has RS-485 output. Both models provide outputs corresponding to an RH range of 0 to 100%.

Temperature measurement range is from -20 to 100 °C, dewpoint measurement from -40 to +80 °C, and absolute humidity from 0.1 to 262 g/m<sup>3</sup>. The unit meets CE requirements.

The HT-737 utilizes a thin-film polymer humidity sensor that provides excellent long-term stability and fast response. The sensor fully recovers from any condensation that may occur.

Because the HT-737 is equipped with a micro controller, it shows

excellent linearity and an accuracy of ±2% RH from 5 to 95% RH. The on-board micro-controller can be programmed, allowing quick and easy calibration without having to access parts inside. The microcontroller eliminates the need for adjustment pots which can contribute to measurement errors.

The size, versatility and durability of the HT-737 make it the ideal choice for all applications that require the monitoring and controlling of humidity and temperature, including many OEM applications.

**Typical Applications**

- ▶ Climate rooms
- ▶ Incubators
- ▶ Bakery machines
- ▶ Greenhouses
- ▶ Warehouses
- ▶ HVAC installations
- ▶ Energy management

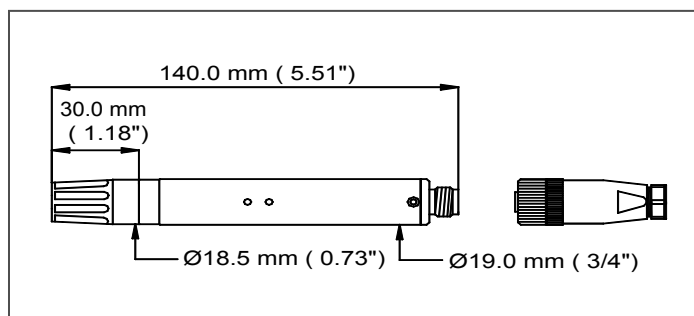

# Transmitter HT-737

## Relative humidity

Range	0 to 100% RH
Output	RS-232 or RS-485
Working range	5 to 95% RH
Accuracy @ 25 °C	±2% RH from 5 to 95% RH
Response time	~10 s typical without filter (90% of the change)
Stability	±2% RH, 24 months typical, depending on environmental conditions
Supply influence	0.01% RH per Volt typical

## Temperature

Range	-20 to +100 °C
Output	RS-232 or RS-485
Working range	-20 to 80 °C
Accuracy	±0.3 °C
Supply influence	±0.01 °C per Volt typical

## Dewpoint

Range	-40 to +80 °C
Output	RS-232 or RS-485
Accuracy	Dewpoint is derived from measured RH and temperature and depends on the combined accuracies of these measured values

## Absolute humidity

Range	0.1 to 262 g/m <sup>3</sup>
Output	RS-232 or RS-485
Accuracy	Absolute humidity is derived from measured RH and temperature and depends on the combined accuracies of these measured values

## Power sup Power Supply

Supply voltage	9 to 30 Vdc
Supply current	~4 mA

## Housing

Dimensions	¾" dia x 5.51" (ø19 x 140 mm)
Material	Plastic
Color	Black
Protection grade	Electronics IP65, sensor IP20 (IP50 with dust filter)

All specifications are subject to change without prior notice.

## Ordering information

Model	Description
HT-737-V-00	Humidity & Temperature Transmitter, RS-232
HT-737-V-01	Humidity & Temperature Transmitter, RS-485
Part number	Accessories
A-000002	Protection cap with slotted openings
A-000014	PVDF dust filter
A-000015	PVDF dust filter including protection cap
A-000021	Protection cap with wire-mesh filter
A-000030	Connector with screws
A-000031	Connector with 6 ft (2m) cable
A-000032	Connector with 16 ft (5m) cable
A-000120	Weather protection cap, wall mount
A-000130	Weather protection cap, cable mount
A-000150	Mini flange, plastic

HEAD OFFICE



*Process Measurement & Controls, Inc.*  
**Rense Instruments Division**

11 Old Sugar Hollow Road  
 Danbury, CT 06810 U.S.A.  
 Tel: 203-792-8686  
 Fax: 203-743-2051  
 Email: [sales@renseinstruments.com](mailto:sales@renseinstruments.com)  
[www.renseinstruments.com](http://www.renseinstruments.com)

Represented By: